



## INSTALLATION AND MAINTENANCE INSTRUCTIONS

# MODEL MSWF AND MSWFA SINGLE WALL FLEXIBLE CONNECTORS



THIS SYMBOL ON THE NAMEPLATE MEANS THE PRODUCT IS LISTED BY UNDERWRITERS LABORATORIES.  
LISTING NO. MH 17528  
(FOR CHIMNEY LINERS)  
LISTING NO. MH 25730  
(FOR VENT CONNECTORS)

## CAUTION:

Metal-fab flexible connector has been designed to properly connect Category I gas-burning appliances to listed chimney-lining systems or listed Type-B gas vent. Category I appliances operate with a non-positive vent static pressure and with a vent temperature that avoids excessive condensate production in the vent. Appliances burning solid or liquid fuels, or category II, III, or IV furnaces, are not to be connected to this flex connector.

Metal-Fab product may be installed in an unenclosed space between the appliance and the listed masonry chimney system or Type-B gas vent. This flexible connector is not listed for use in an attic or crawl space. This flexible connector must not pass through any combustible structure such as a wall, ceiling, or floor. Contact local building or fire officials about restrictions and installations in your area.

The flexible connector must not be sized less than that specified in the appliance manufacturers instructions.

Clearances for Metal-Fab flexible connector to unprotected combustible material is 1" in open air space. This product is not intended to be used in applications where Type B gas vent is required as the connector. Do not fully enclose or pass through combustible areas such as walls, ceilings, floors, attics, or crawl spaces. If connecting to a flexible chimney liner, refer to the "Minimum Appliance Clearances" specified in NFPA 211.

To properly size the connector, follow the Category I venting table now contained in the National Fuel Gas Code (NFPA 54/ANSI Z223.1).

While installing flexible connectors, consideration should be given to the following:

1. Make no unnecessary bends
2. Make no bends greater than 90 degrees
3. Make bends as smooth as possible, with no dips or snags, and
4. Install with at least a 1/4" per foot rise
5. Metal-Fab's flexible connectors are available in 1ft, 2ft, 3ft, 4ft and 5ft lengths.

### INSTALLATION:

1. Determine the length of the connector needed to connect an appliance to:
  - a. Inlet of listed chimney lining system, or
  - b. inlet of Type-B gas vent pipe, Tee, or "Y".
2. Never cut or modify the flexible connector length. Choose connector lengths which provide the proper overall length. Length can be reduced slightly by compressing the flexible connector.
3. Twist lock the outlet (top end of the connector to):
  - a. The inlet of the chimney lining system, (See **FIG. 1**)
  - b. Inlet of the Type-B gas vent system (See **FIG. 2**), or
  - c. Inlet end of Type-B gas vent Tee or "Y" (See **FIG. 3**).

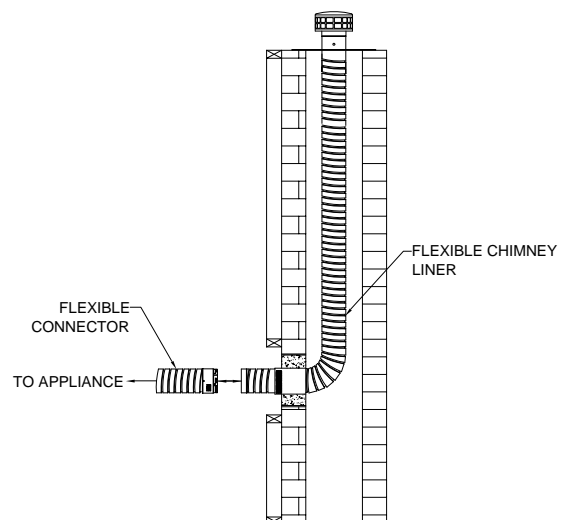

FIG. 1

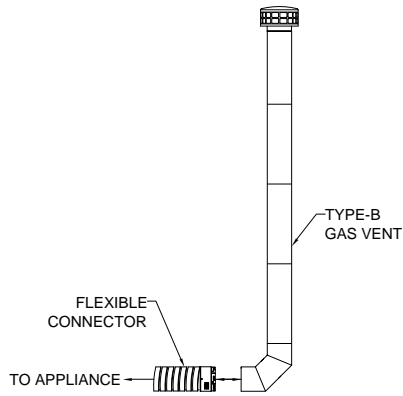

FIG. 2

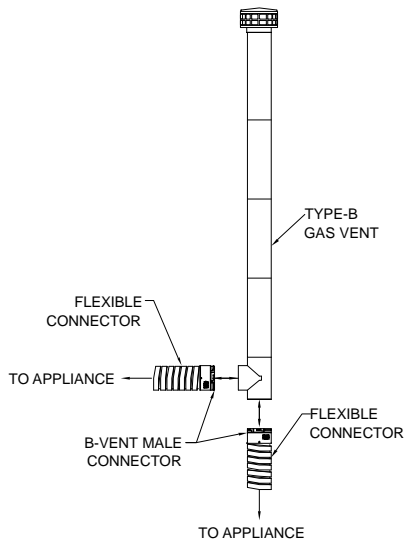

FIG. 3

4. Form the flexible connector(s) into the configuration that enables connection to:
- A single appliance (See FIG. 4) or
  - Multiple appliances (See FIG. 5).
- Be careful not to make any abrupt or sharp bends or create bends greater than 90 degrees.

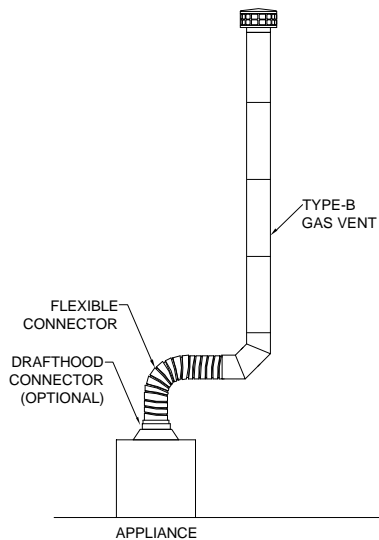

FIG. 4

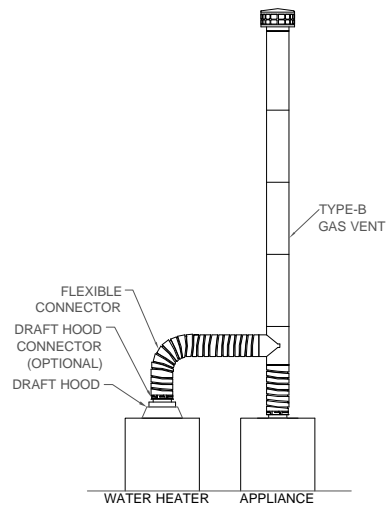

FIG. 5

5. Attach the inlet (bottom of the connector) to the appliance or to a draft hood connector (See FIG. 6).

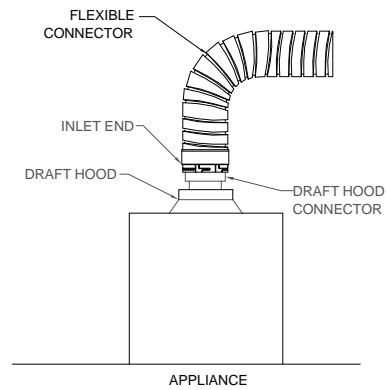

FIG. 6

6. After making all connections, check the system for soundness of connections and compliance with clearance to combustibles.

**MAINTENANCE INSTRUCTIONS:**

A qualified person should check the flexible connector at least once per year following initial installation, to insure connections are tight and the flexible connector has not sagged.



P.O Box 1138 • Wichita, KS 67201  
(316) 943-2351 • FAX (316) 943-2717