

**INSTALLATION AND MAINTENANCE
INSTRUCTIONS FOR MODELS M & MO
GAS VENTS (B-VENT)**



This symbol on the nameplate means this product is listed by Underwriters Laboratories, Inc. Listing No. MH7860 Testing No. 441

GENERAL:

The Model M and MO Gas Vents (B-Vent) have been designed for use with gas burning Category I appliances. A Category I appliance operates with a non-positive vent static pressure and with a vent temperature that avoids excessive condensate production in the vent.

B-Vent is of double wall construction, with the inner flue of aluminum alloy (allowing rapid warm-up and better draft) and the outer casing of galvanized steel or galvalume steel.

Model M B-Vent is compatible with listed masonry relining systems, single wall connectors and other listed gas vents. Model M B-Vent may be used to reline masonry chimneys (Separate instructions are available from Metal-Fab).

Model MO, Oval Gas Vent is designed for installation within 2" x 4" or 2" x 6" wall studs and for venting of wall mounted furnaces. Transition from oval to round for lowest cost installation is easily obtained.

SAFETY:

CAUTION: UL listing is based on using B-Vent components supplied by Metal-Fab, Inc. Performance may be affected and a safety hazard created if parts shown in these instructions are not used.

1. Metal-Fab B-Vent pipe and fittings were designed and are listed to form a continuous passageway from the gas burning appliance to the vent termination above the roof, including the vent cap.
2. These B-Vent components are to be installed with minimum one inch clearance to combustible material. Strap vent in place, especially on lateral or horizontal runs, to maintain proper clearances to combustibles. Do not pack insulation or other materials around the B-Vent.
3. When installing B-Vent always align "Up" arrow away from appliance.
4. Locate vent as close as possible to appliance to obtain maximum draft and minimize connector pipe length.
5. For horizontal runs, maintain a pitch or rise from the appliance. Minimum rise is 1/4 inch (6.4mm) per foot (305 mm).
6. A B-Vent Cap should be used on all installations to prevent back drafts and to keep out rain and debris. The vent must extend through a flashing, and should terminate with the lowest discharge opening no closer to the roof than the minimum height shown in the table below. These minimum heights may be used provided the vent is not less than 8' from any vertical wall. For installations not covered in TABLE 1, including sizes larger than 12", the lowest discharge opening of the vent cap should be at least 2' above the highest point where it passes through the roof, and at least 2' higher than any portion of a building within 10' horizontally. All gas vents extending above the roof more than 5 feet must be securely guyed or braced.

TABLE 1

Roof Pitch	Minimum Height
Flat to 7/12	(305 mm) 1.0 ft
Over 7/12 to 8/12	(451 mm) 1.5 ft
Over 8/12 to 9/12	(610 mm) 2.0 ft
Over 9/12 to 10/12	(762 mm) 2.5 ft
Over 10/12 to 11/12	(991 mm) 3.25 ft
Over 11/12 to 12/12	(1218 mm) 4.0 ft
Over 12/12 to 14/12	(1524 mm) 5.0 ft
Over 14/12 to 16/12	(1829 mm) 6.0 ft
Over 16/12 to 18/12	(2134 mm) 7.0 ft
Over 18/12 to 20/12	(2286 mm) 7.5 ft
Over 20/12 to 21/12	(2438 mm) 8.0 ft

7. Vent sizing is defined by tables in NFPA54 (ANSI Z223-1, 2015), or contact your Metal-Fab supplier. Install in accordance with these instructions and local code requirements.

Round Sizes 3" (76mm) - 14" (355 mm)
Oval Sizes 4" (102 mm) - 6" (152mm)

8. B-Vent is to be used to vent listed gas appliances intended to burn only gas. Type B-Vent is **NOT** to be used with the following:
 - A. Unlisted Gas Appliances
 - B. Incinerators
 - C. Recessed Heaters
 - D. Conversion Burners
 - E. Gas/Oil Burners
 - F. Any appliance which may be readily converted to a solid or liquid fuel.
 - G. Any other appliance NOT intended to burn only gas.

In areas where solid or liquid fuels are common, the vent location should be marked "For use with vented appliances burning only gas".
9. Venting into an unlined masonry chimney may cause condensation. Install B-Vent or Metal-Fab metal liner inside the chimney to prevent condensation.
10. When installing exterior vent, not enclosed by the structure or a chase, consult local gas utility, appliance manufacturer, and/or authority having jurisdiction.
11. If a power vent fan is used, make sure it is located at the terminus (exhaust end) of vent system, so as to maintain negative pressure within the vent.
12. A B-Vent support plate (MSP) is required if vertical height exceeds 30 feet. Maximum of 30 feet between supports.

INSTALLATION:
Round B-Vent

The Type M B-Vent sections and components 3"-14" diameter use the Metal-Fab positive twist lock for interconnections. Align the ends of the vent, push together then twist section to lock in place. Use SureLock™ tab on 3"-6" sizes only. See DETAIL 1.

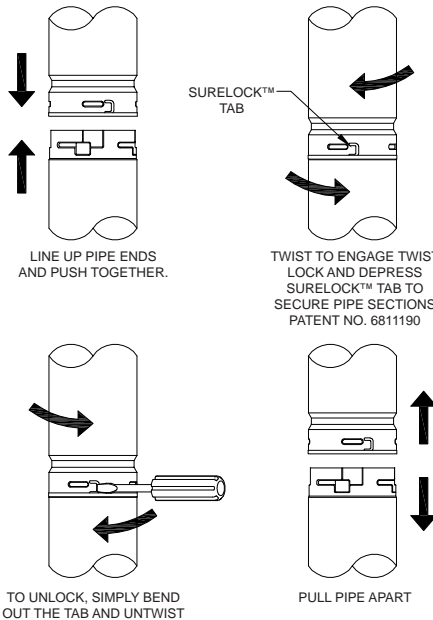

DETAIL 1 - INSTALLATION INTERCONNECTIONS

No additional fasteners are required to assure a safe installation. It is acceptable to apply screws at the joints if local code requires, or at the installing contractor's option, provided that the screws do not penetrate the flue.

1. Starting at the appliance outlet, attach the first section. It is acceptable to use screws to attach the B-Vent to the appliance outlet. If the appliance has a draft hood, the MDC draft hood connector is attached to the top of the draft hood and the first B-Vent section is twist-locked to the MDC.

2. If this is a single, straight up installation, and the B-Vent must penetrate the ceiling, cut a hole in the ceiling 2 inches (51 mm) larger than the outside diameter (OD) of the outer casing. The B-Vent is to be centered in this opening. When installed, check to make sure the one inch (25.4 mm) clearance to combustible has been maintained. (See FIGURE 1).

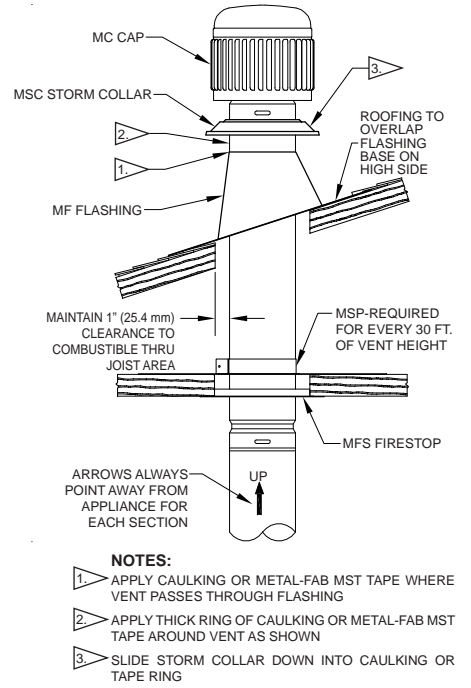

FIGURE 1

3. When a combustible floor is penetrated by B-Vent, a MFS firestop or MSP support plate is used to close the opening. If the area above the ceiling is an attic, the firestop or support plate is mounted above the joist to assure that insulation does not drop into the joist area.
4. Continue with B-Vent penetrating the roof.

NOTE: For Canadian installations, use labeled ULC section, designated with Suffix G, on vent sections exposed to atmosphere.

At the roof, the opening should be 2 inches (51 mm) greater than the B-Vent OD. Above the roof, a flashing is required to maintain the one inch (25.4 mm) clearance to the combustibles of the roof. Installation of a storm collar allows water to drain over the flashing. Caulk as shown in FIGURE 1.
5. Install the B-Vent cap (MC) onto the B-Vent.

NOTE: See height of vents under "SAFETY".
6. If a UL Listed gas vent other than Metal-Fab is to be connected to the inlet end of the Metal-Fab B-Vent, use the M6A, M12A, or M18A gas vent adapter. Insert the male end of the other gas vent into the gas vent adapter and secure by tightening the clamp on the adapter (See FIGURE 2A). If Metal-Fab B-Vent is to be inserted directly into the inlet end of a UL Listed gas vent other than Metal-Fab, secure by using three (3) 1/4 inch (6.4 mm) long sheet metal screws. Do not penetrate the flue (See FIGURE 2B).

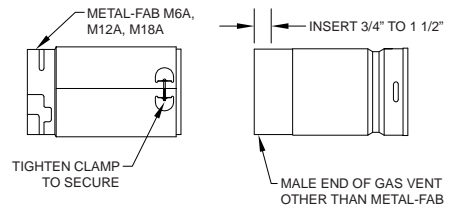

FIGURE 2A

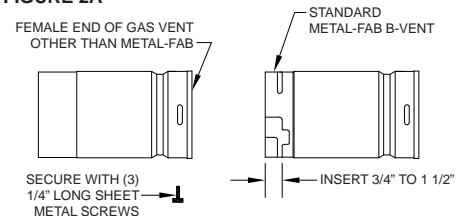

FIGURE 2B

7. Although it is not a preferred practice, there may be installations where B-Vent must run vertically-exterior to the building-and wall support is needed. A wall band (MH) or (MWB) is used by placing around the B-Vent, then fastening to the wall. Using a wall band assures that the clearance to combustibles is maintained (See **FIGURE 3**).
 - a. Cut a hole in the outside wall 1/4" larger than the diameter of the sleeve on wall thimble (MPT).
 - b. Install the wall thimble by inserting the larger of the two parts on the appliance side and the other half through the outside wall.
 - c. Install chimney sections vertically, starting at the tee. Attach a wall bracket every six feet to secure the vent to the wall.

NOTE: A minimum clearance of 1" (25.4 mm) to combustibles is required.

- d. Make remainder of vent installation per B-Vent installation instructions.

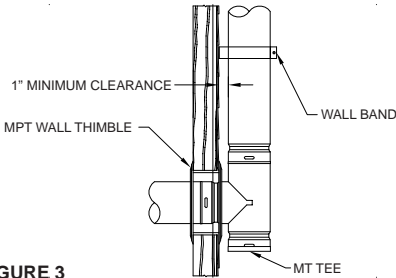

FIGURE 3

8. When the connector from the appliance is single wall, it must terminate into B-Vent. At this termination, it is acceptable to secure the joint with sheet metal screws.

NOTE: Single wall connector, either rigid or flexible, cannot be enclosed within combustible materials.
9. If the installation requires two appliances to terminate into a common B-Vent, a B-Vent wye or tee is used. It is recommended that the higher output appliance, normally the furnace, insert into the bottom of the wye or tee and the other appliance attach to the top. To minimize the length of run and to provide maximum flexibility in these installations, a swivel tee (MST) or swivel wye (MSY) is used. These components provide 360 degrees of rotation to position the tap in the proper orientation (See **FIGURE 4**).

NOTE: Consult the Metal-Fab catalog for the many variations of wyes and tees available.

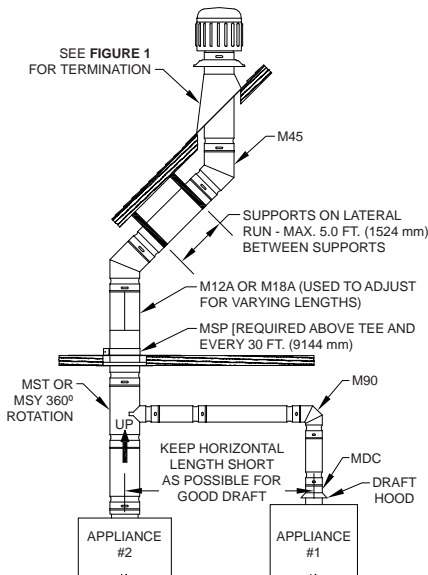
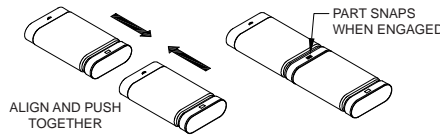

FIGURE 4

10. It is a common practice to utilize the 90 degree adjustable elbow (M90) in the appliance area to minimize vent run. Use of the M90 or M45/60 elbow is acceptable and not limited to the appliance area.
11. For horizontal and lateral runs, it is recommended that support be used every 5 feet (1524 mm). Plumber's straps are commonly used. They should be positioned to maintain 1 inch (25.4 mm) clearance to combustibles.
12. If your installation requires a change in diameter due to vent capacity, a B-Vent increaser (MI) is available. Installation is the same as standard B-Vent Sections.

Oval Vents

The 4MO and 5MO oval vents are listed for use in either 2" x 4" or 2" x 6" stud walls, with firestop/spacer to maintain proper clearance to combustibles. The 6MO is listed for use in 2" x 6" stud wall. The firestop/spacer is to be located centrally between studs spaced not less than 16" on centers. The oval vent is interlocked by pushing together. See **DETAIL 2**.



DETAIL 2 - STYLE M OVAL INTERCONNECTIONS

The 4MO has a dual listing as MO and BW oval vent. The 4BW is used with recessed heaters with maximum output of 85000 BTU/HR (25 KW) for single story and 65000 BTU/HR (19 KW) for multistory installations.

1. Normally the appliance outlet is of a round shape, therefore, a B-Vent Section or Draft hood connector (MDC) will be attached to the appliance. To transition to oval sections, a Round to Oval Adapter (MRO) is required. The floor and ceiling plates must be cut away to allow placement of the oval. To position the oval, and maintain clearance to combustibles, a firestop (MOFS) is used at the floor and the ceiling (See **FIGURE 5**).
2. If the appliance is in the same room as the entry to oval vent, the oval tee (MOT) can be installed in the wall studs. To close the bottom of the Tee, use the Tee Cap (MOTC). To support the tee within the wall studs, use the Tee Support (MOTS). As the oval vent continues upward, use the MOFS at the ceiling level (See **FIGURE 5**).

SAFETY CAUTION: 5MO oval vents should not be used in 2" x 4" stud walls when used to vent a gas fireplace. In this application, install 5MO in 2" x 6" stud wall only.

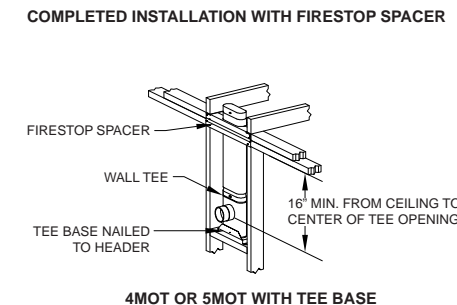
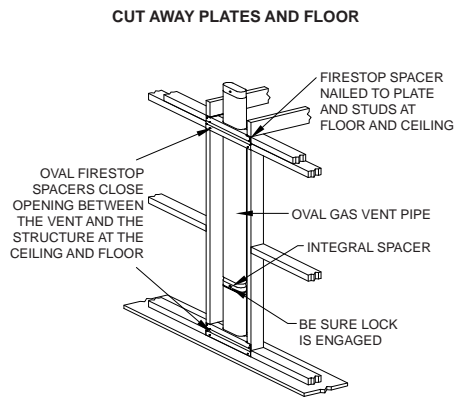
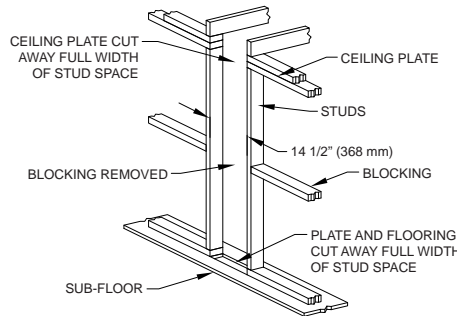

FIGURE 5

3. Normally, in the attic area, the oval vent transitions back to the round using the Oval to Round Adapter (MOR). The installation is then terminated as a round B-Vent, as previously explained.
4. If your installation terminates as oval, the Oval Flashing (MOF) and Oval Storm Collar (MOSC) are shown in **FIGURE 6**. An Oval Vent Cap (MOC) completes the installation.

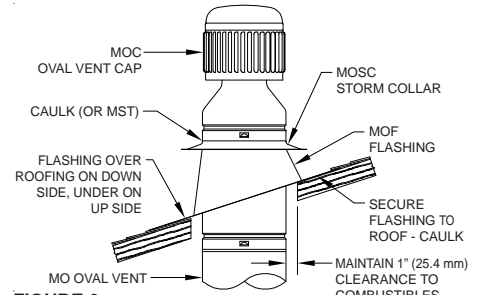

FIGURE 6

5. Because oval vent lengths may not meet your specific run, the Oval Adjustable Length (MOA) is used to adjust for length differences. The female end of the MOA accepts the male end of the Oval Section. When the correct length is achieved, the clamp on the MOA is tightened. The male end of the MOA snaps into the next oval section.
6. If, within the stud wall, a direction change is required, the 45 degree flat elbow (MO45F) is available. If the directional change occurs as the vent is exiting the stud wall, the 45 degree standard elbow (M045S) is used. Increasers (MOI) are available to go from 4MO to 5MO or to 6MO.
7. If the installation is with a recessed heater, the 4MOK installation kit is required. At the top of the recessed heater mounted in the stud wall, the gasket is applied under the base plate from the 4MOK. The base plate is screwed to the heater outlet. The base plate has provisions to allow 4BW vent to snap in place. At the ceiling level, the ceiling plate spacers are mounted to maintain proper clearances to combustibles. At this point the installation is the same as explained earlier (See **FIGURE 7**).

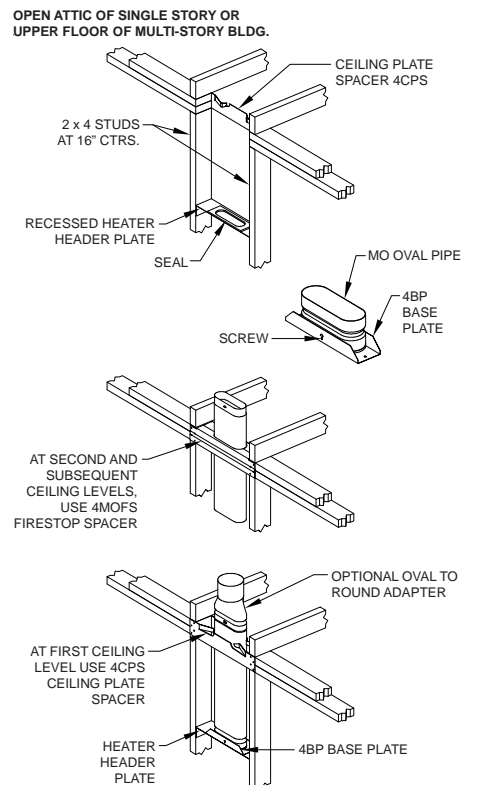

FIGURE 7

MAINTENANCE:

Gas vent systems normally operate trouble free. Conduct a yearly inspection of the system, and replace any damaged parts.

NOTE: If extreme weather conditions occur, inspection of all exposed vent components is necessary. Replace any damaged parts.